



# Atmospheric Vented Gas Water Heaters

Proven technology. Exceptional reliability. Peace-of-mind.

With over four billion hours of trouble-free performance in the field and more than 800,000 installations, GSW Flame Guard® system gas water heaters are the only Flammable Vapour Ignition Resistant (FVIR)-compliant water heaters on the market with over five years of proven performance. FVIR water heaters are designed to keep burning vapours inside the combustion chamber until they burn out. A sensor inside the water heater will detect if it has ignited a flammable vapour from outside of the water heater and shut off the flow of gas to the burner and pilot light.

Flame Guard® patented technology prevents the ignition of flammable vapours from products such as gasoline, paint thinner and solvents. Subjected to over 1,000 tests including lint, dust and oil, butane and endurance burn, the Flame Guard® system is the safest and most proven technology available today.

## PRODUCT FEATURES:

- Same footprint as existing heaters making them perfect for replacement
- Turbulator™ dip tube for self-cleaning, reducing sediment at the bottom of the tank and increasing hot water output by as much as 8%
- Over 20% more foam insulation and a higher EF for energy and cost savings

## BENEFITS OF THE FLAME GUARD® SYSTEM

### Servicing made simple – saves you time and money

- Combustion chamber is easy to access
- T&P valve is conveniently located at the side of the tank to facilitate piping to a drain or outside the building
- Piezoelectric ignitor allows for lighting of the pilot without matches
- Dependable three-leg design for better leveling and access to flame trap

### Long-lasting dependability means years of assurance

- Glass-lined inner flue prevents scaling
- Top-mounted heavy duty anode rod for added tank protection
- Robust 1/4" pilot tubing



# GSW Atmospheric Vented Gas Water Heaters

## NATURAL GAS

WARRANTY	MODELS	RATED CAPACITY			INPUT * BTU PER HR.	RECOVERY @ (100°F/45°C)			ENERGY FACTOR	A	B	Approx. Ship Wt. lb / kg	FLAME GUARD®
		US GAL	IMP. GAL	LITRES		USG/h	IG/h	LITRE/H		JACKET DIA. in / cm	Top of Vent in / cm		
6	SS19NA	19	16.2	72	22,000	18	16	69	0.58	18 / 46	37 / 95	81 / 36.8	YES
6	G630S27FV	30	25	113	27,000	22.9	20.4	86.7	0.61	19 / 48.3	49.8 / 126.5	108 / 47	YES
6	6G40S38ES	40	33.3	151	38,000	32.2	26.8	121.8	0.62	21 / 53.34	53 / 134.6	136 / 64	YES
6	6G40T40ES	40	33.3	151	40,000	32.2	26.8	121.8	0.62	19 / 48.3	63.3 / 161	136 / 64	YES
6	6G50S40ES	50	41.6	189	40,000	33.9	28.2	128.2	0.62	22.5 / 57.2	54.5 / 138	160 / 74.8	YES
6	6G50T40ES	50	41.6	189	40,000	33.9	28.2	128.2	0.62	21 / 53.34	62 / 157	155 / 70	YES
6	6G60NA	60	50	227	52,200	52.2	43.47	197.62	0.56	22.5 / 57.2	62.5 / 160	181 / 85	YES
6	6G-75-3NC	75	62	284	76,000	66.6	55.46	252.13	0.53	26 / 66	66 / 168	283 / 128	

## PROPANE

WARRANTY	MODELS	RATED CAPACITY			INPUT BTU PER HR.	RECOVERY @ (100°F/45°C)			ENERGY FACTOR	A	B	Approx. Ship Wt. lb / kg	FLAME GUARD®
		US GAL	IMP. GAL	LITRES		USG/h	IG/h	LITRE/H		JACKET DIA. in / cm	Top of Vent in / cm		
6	GP630S27FV	30	25	113	27,000	25	20	92.7	0.61	19 / 48.3	49.8 / 126.5	108 / 47	YES
6	GP640S38FV	40	33.3	151	38,000	32.2	26.2	121.8	0.59	21 / 53.34	53 / 134.6	136 / 64	YES
6	GP640T40FV	40	33.3	151	40,000	32.2	26.2	121.8	0.59	19 / 48.3	63.3 / 161	136 / 64	YES
6	GP650S40FV	50	41.6	189	40,000	33.9	28.2	128.2	0.59	22.5 / 57.2	54.5 / 138	160 / 74.8	YES
6	GP650T40FV	50	41.6	189	40,000	33.9	28.2	128.2	0.59	21 / 53.34	62 / 157	155 / 70	YES
6	6G-75-3PC	75	62	284	76,000	60	50	227.2	0.53	26 / 66	66 / 168	283 / 128	

\*Inputs are based on sea level (0-2,000 ft) models. High altitude (0-4,500 ft) models are de-rated by 10% as per CSA.

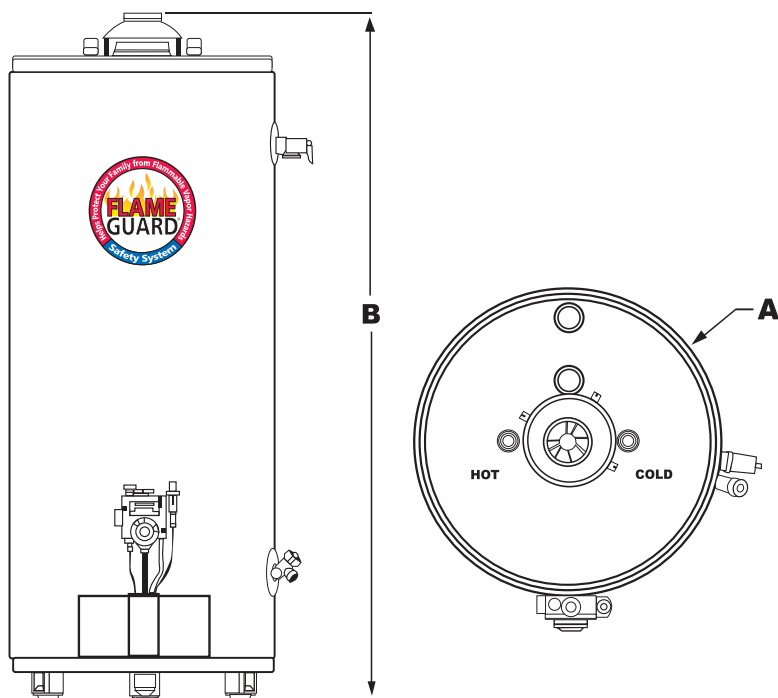

### GSW Warranty:

All GSW Water Heaters will be replaced free of charge in the case of tank leakage within the stated warranty period from the date of installation in domestic applications, and one year in commercial applications. All parts supplied are warranted for one year. Warranty does not include labour. Consult owner's manual for complete details.

### GSW Water Heating HEAD OFFICE:

599 Hill Street West  
Fergus, ON, Canada N1M 2X1  
Tel: 888-599-2837  
Fax: 519-787-5500  
E-mail: [gswinfo@gsw-wh.com](mailto:gswinfo@gsw-wh.com)  
[www.gsw-wh.com](http://www.gsw-wh.com)

