



The Quiet Tradition Continues...

With an advanced line of sealed combustion power direct vented water heaters.



The Power Direct Vent™ (PDV) is designed with a sealed combustion chamber, ultra-quiet blower and state-of-the-art gas control for highly accurate and reliable temperature control.

Perfect for both residential new home construction and replacement water heater applications, the Power Direct Vent™ will provide the ultimate solution for your hot water needs.

WATER HEATER FEATURES

Energy Savings

- Exceeds energy efficiency standards
- No heated indoor air used for combustion

High Quality Features

- All units meet ENERGY STAR® requirements
- Exclusive patented TankSaver® design to prolong tank life
- Low-profile design is ideal for replacement applications
- Conveniently located T&P and drain valve for serviceability

Industry Leading, Ultra-Quiet Blower

- Continues the GSW tradition of quiet power vent water heaters

Sealed Combustion Chamber Design

- Prevents accidental ignition of flammable vapours
- Enhances air quality as no indoor air is required for combustion
- Great for tight space installations

Flexible Venting Configurations

- **NEW!** Can be vented with ULC S636 approved PVC or CPVC up to 50 equivalent feet, horizontally through the wall or vertically through the roof (see installation manual for full details)
- Auto-reset temperature switch monitors vent temperature

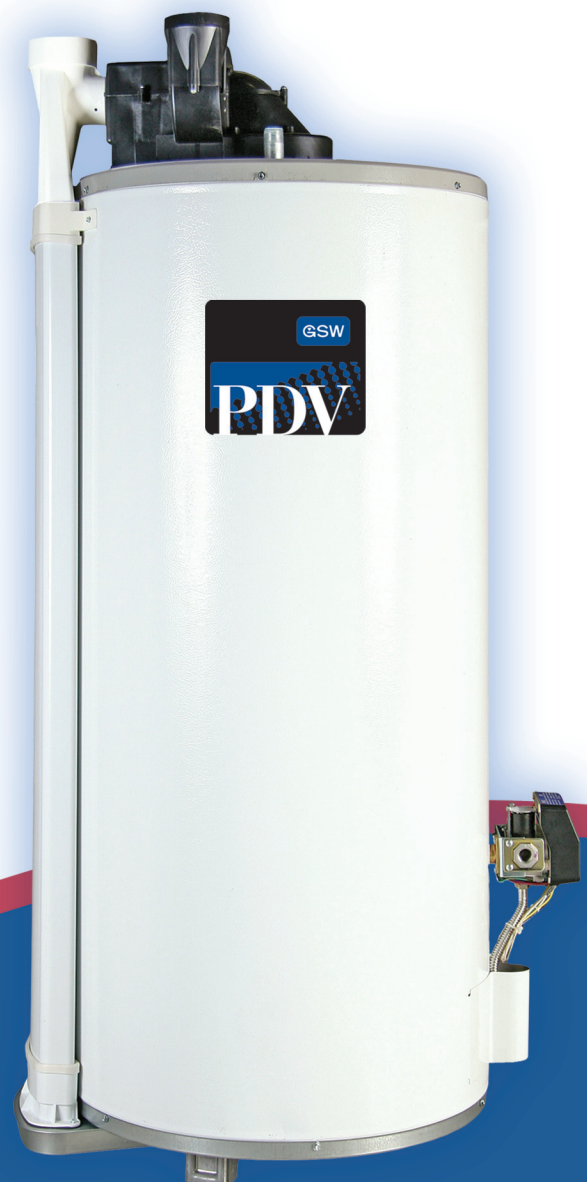

An advanced line of sealed combustion power direct vented water heaters.

CAPACITY & DIMENSIONS

Model	Capacity USG (Litres)	BTU Input	Recovery @ 100°F/55°C Rise USG (Litres)	Energy Factor	Height to Top of Blower A in. (cm)	Height to Top of Tank B in. (cm)	Diameter C in. (cm)	Overall Depth D in. (cm)	Vent Diameter in. (cm)	Approximate Shipping Weight lb. (kg)
NATURAL GAS										
6G4040SN-PDV-ES2	40 (151)	40,000	33.93 (128.44)	0.67	59.5 (151.1)	51 (130)	22.6 (57)	25.38 (64.46)	2 (5.1)	162 (73)
6G5040SN-PDV-ES2	50 (189)	40,000	33.93 (128.44)	0.67	68.5 (174.0)	60 (152)	22.6 (57)	25.38 (64.46)	2 (5.1)	182 (82)
6G5065SN-PDV-ES2	50 (189)	65,000	64.5 (244)	0.67	69.75 (177.2)	61.25 (155.6)	22.6 (57)	25.38 (64.46)	3 (7.6)	209 (95)
PROPANE										
G4040SP-PDV-ES2	40 (151)	40,000	33.93 (128.44)	0.67	59.5 (151.1)	51 (130)	22.6 (57)	25.38 (64.46)	2 (5.1)	162 (73)
G5040SP-PDV-ES2	50 (189)	40,000	33.93 (128.44)	0.67	68.5 (174.0)	60 (152)	22.6 (57)	25.38 (64.46)	2 (5.1)	182 (82)

High altitude models are de-rated by 10% as per CSA.

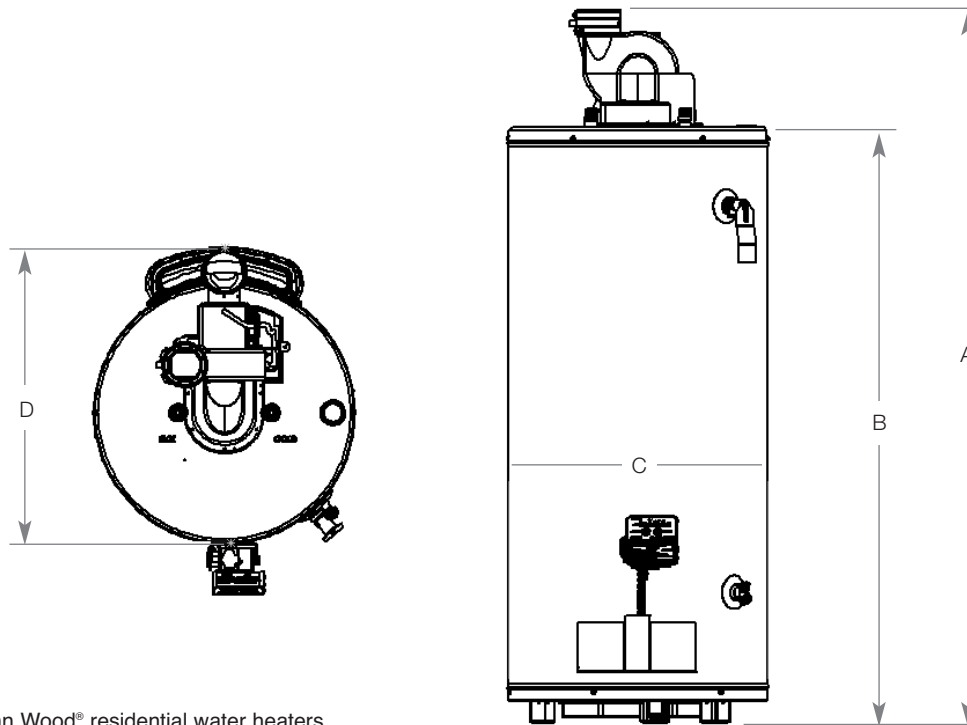

GSW Warranty:

All GSW and John Wood® residential water heaters will be replaced free of charge in the case of tank leakage within the stated warranty period from the date of installation in domestic applications, and one year in commercial applications. All parts supplied are warranted for one year. Warranty does not include labour. Consult owner's manual for complete details.



GSW Water Heating HEAD OFFICE:

599 Hill Street West
 Fergus, ON, Canada N1M 2X1
 Sales/Customer Service: 888-599-2837
 Fax: 519-787-5500
 Technical Support and Warranty: 1-888-479-8324
 E-mail: info@gsw-wh.com
 Website: www.gsw-wh.com